

STOL CH 801 ELEVATOR ASSEMBLY - SECTION 2
"INSTALLING SKINS"



CAUTION: to avoid kinking the bent trailing edge, move the skin by lifting up along the front edges, to not handle the bent trailing edge.

With a marker, mark the rivet line in the middle of the flanges: rear ribs, spar and nose ribs. Standard edge distance is 9 to 10mm



ELEVATOR REAR SKIN
8H6-1 qty=1



Slide the skeleton into the pre-bent rear skin 8H6-1.

DUCT TAPE

Use duct tape to tape one side of the skin flush with the spar web (front of spar)

The preferred method is to use duct tape instead of the clecoes shown on the photo.

ALIGNMENT: Line up the pilot holes in the skin with the rivet lines marks on the spar and rib flanges (with a straight edge and marker, extend the rivet lines to the edge of the skin for more exact alignment).



RIB ALIGNMENT

Lift up on the nose rib to raise the skeleton to reach inside to adjust the position of the rear rib: view through the pilot holes in the skin the rivet line on the rib flange.

REFERENCE:

Before drilling, keep the assembly flat on the workbench.

CHECK

Check the rib alignment along the entire length of the rib prior to drilling.

Start drill from the rear forwards (first Cleco two holes in each ribs, then finish drilling between the clecos – additional clecos are not required).



SECOND SIDE

Drill & Cleco the second side. Place the assembly in the elevator stand (jig) Ref drawing 8S-S



Wait to drill the skin to the channel 8H3-2. This will be done in the next section when the upper and lower Elevator Horns 8H5-1 and 8H5-3 are installed.

NOTE: The gap at the end of the rib is left open.

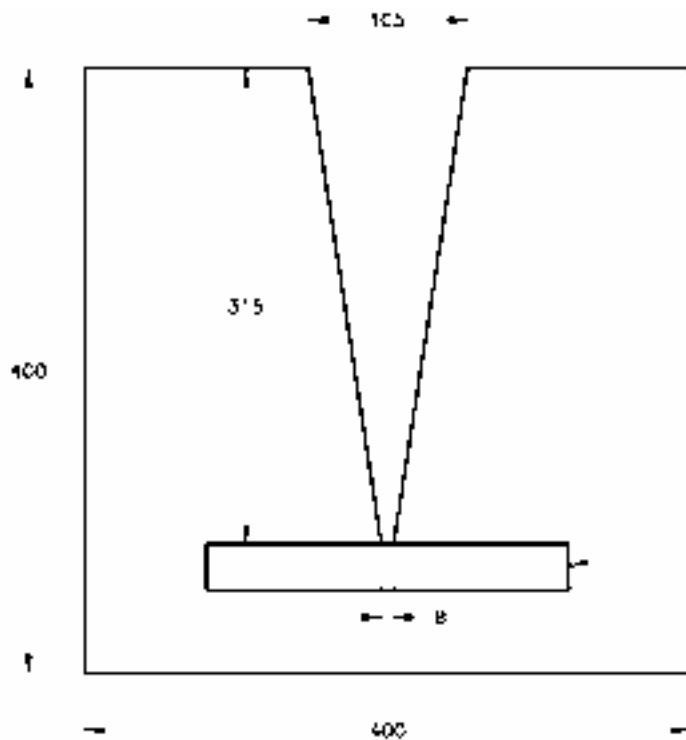

PLYWOOD ENDS
2 REQUIRED

STOP BLOCK SCREWED TO THE ENDS
THE BLOCK ALSO PREVENTS ANY
DAMAGE TO THE TRAILING EDGE

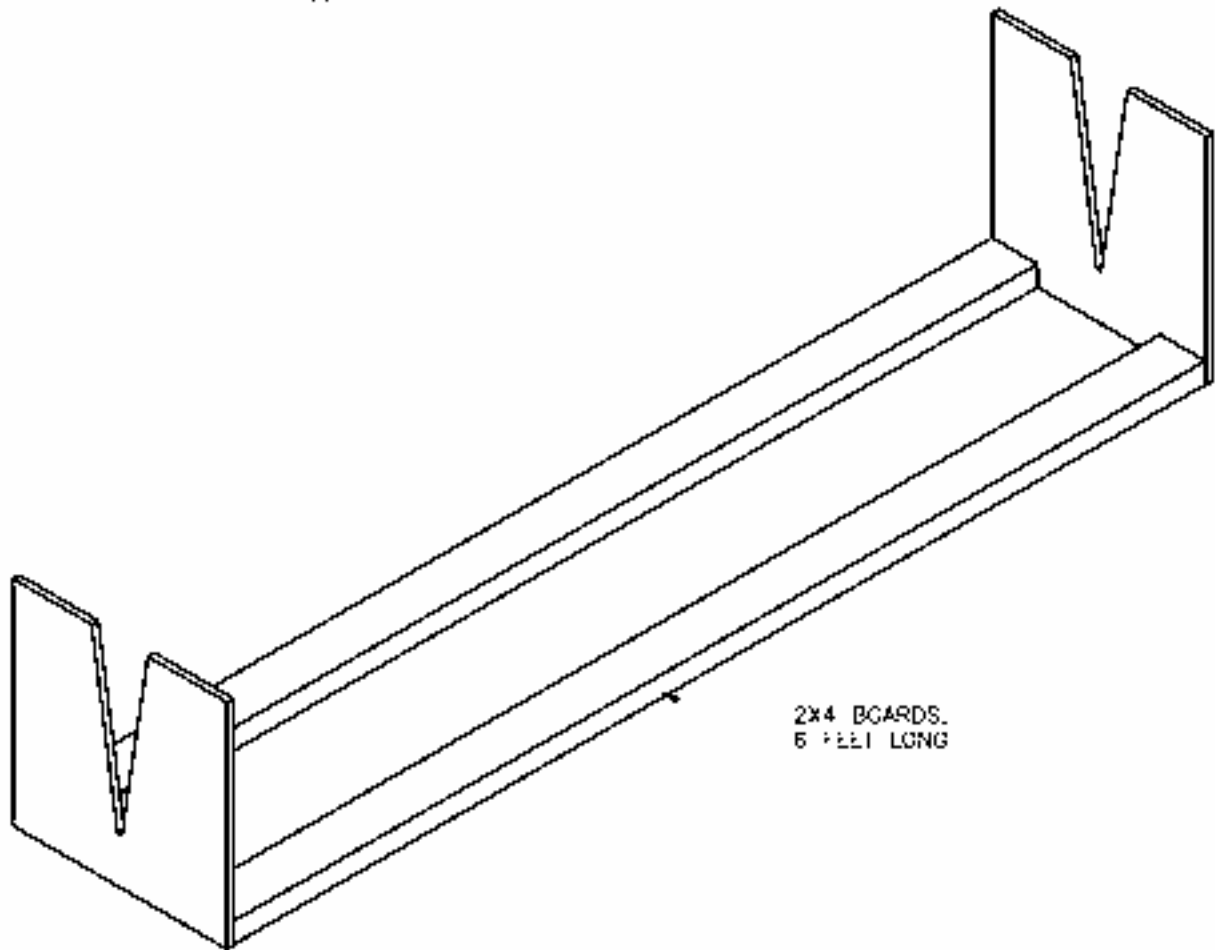

2x4 BOARDS,
6 FEET LONG

801 ELEVATOR STAND TO INSTALL THE NOSE SKIN.



RIVET LAYOUT ON TIP RIBS and NOSE RIBS

The nose and tip rib **rivets** are located on center between the rib crimps. Mark the location of the rivets onto the side of the nose and tip ribs. Do not plan to place a rivet after the last crimp closest to the tip. The flange at this point is too narrow.

4 RIVETS A5

(4 on top and 4 in bottom flange)



ELEVATOR NOSE SKIN

8H6-2 qty=2

LAYOUT:

Mark the rivet line 10mm from the edge the full length of eachside.

Measure and mark your skin to indicate, "Top side".
The short side is the top (180mm. from center of radius).



Position the skin on the leading edge of the ribs to mark the location of the Nose Rib 8H1-6 on the skin. Do not strap down, this first fitting is to locate the rivet line for the nose rib.

ALIGNMENT:
Line up the outboard edge of the skin even with the rear skin.

Line up the center of the radius of the skin with the leading edge of the ribs.



NOSE RIB REFERENCE:
Mark the flange center line of the nose rib 8H1-6 on the aft edge of the skin.

Remove the skin, with a square on the aft edge mark the rivet line on the skin.

CHECK:
Rivet spacing is between the crimps, the first rivet is not in the spar.

Layout the 4 rivets and drill #40 pilot holes

COMMENT: When the Jig 8S-S is used, it is not necessary to rivet the rear skin before the nose skin is installed.



It is important to inspect the elevator at this time for any twist, which may be caused by the installation of the nose skin. Stand eight to ten feet away from the end of the elevator and sight down its length paying particular attention to alignments at the very tip of the leading edge.

Position the Nose skin and strap it down. The nose skin overlaps on top of the rear skin.



With the nose skin firmly strapped in place mark the spar rivet line through the middle of the spar flange 8H3-5

A5 PITCH 40

Slide nose skin into place.



An alternative method of checking alignment of nose skin
The line on the nose skin is the centers marked earlier.

Check alignment at elevator ends.



Check skin alignment at center of elevator.
Layout the centerline on both ends of each skin.



On final assembly, the nose skin should be on the outside of the rear skin.

A5 PITCH 40
Spar rivet line

With the skins firmly strapped in place proceed to drill the spar rivet line through both the nose and rear skins. #30 drill. Cleco well as drilling proceeds.

Re-inspect the skin alignments and drill the spar lines on the opposite side of both sets of skins.

Transfer the nose and tip rib rivet centers to the nose skin and drill those holes with #30 drill.

Remove the nose skin, deburr, and trim the edge for proper edge distance (10 mm. from holes).

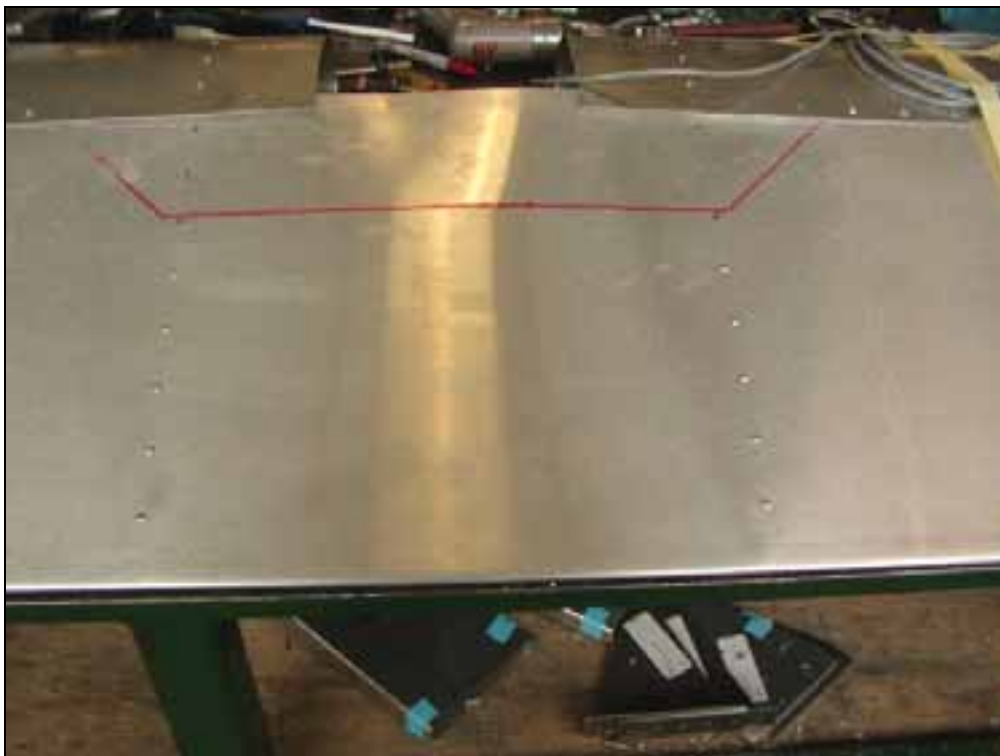

**ELEVATOR GUSSETS
(TOP AND BOTTOM)
8H6-4 qty=2**

Location of Gusset on elevator: can either be installed to top of the elevator rear skin 8H6-1 or it can be installed underneath the skin (between the skin and the skeleton).

Ref see drawings
8XH-2 and 8HA-1

Additional gusset: top and bottom
either on top or under the skin

$t = .025$

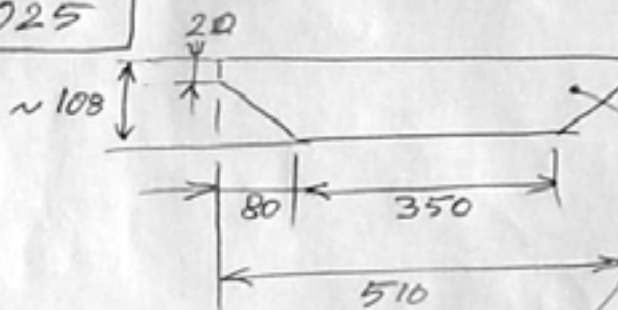

**ELEVATOR GUSSETS
 (TOP AND BOTTOM)
 8H6-4 qty=2**

t=.025"
 length = 510mm
 width = 108mm

Front rivet line is through
 the elevator spar 8H3-5,
 the rear rivet line is
 through the elevator
 channel 8H2-14

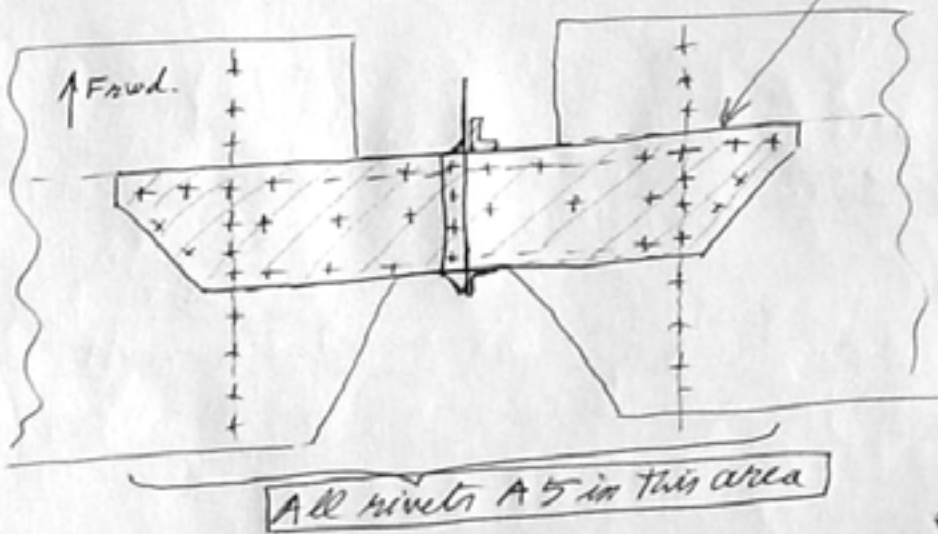

All rivets A5 in this area

A5 RIVETS

NOTE: The middle rivets
 are through the Horns
 8H5-1 and
 8H5-2

NO RIVET ZONE: Wait to
 drill the middle rivets until
 after the Horns are
 positioned.

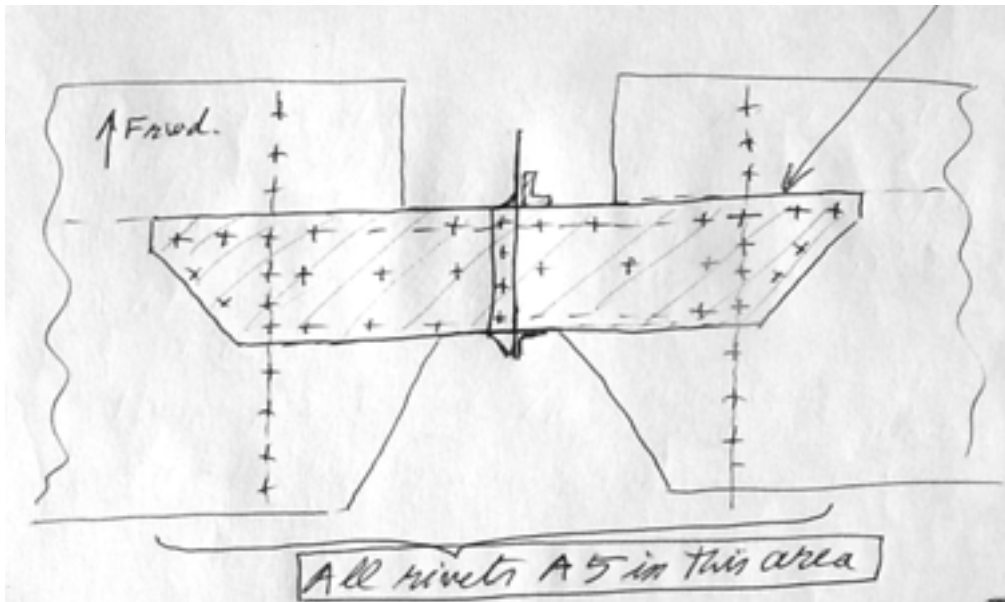

All rivets A5 in this area

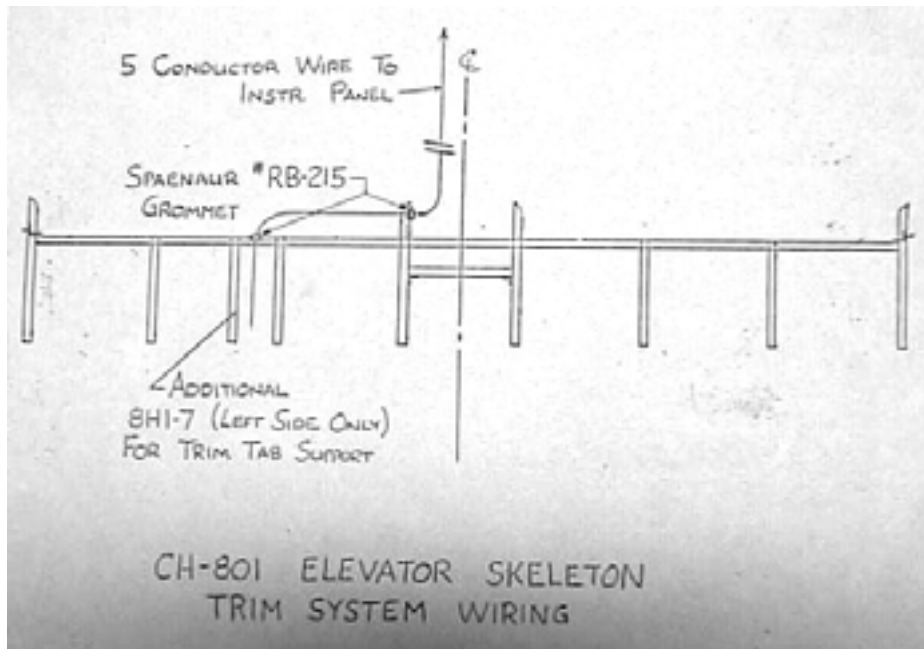

GROMMETS AN931-3-5

Install the grommets and wire for the trim motor.
Trim tab: see section 4

To install the grommets drill a 3/16" hole in the spar web and the rib.

After the nose skin is in place, tuck the end of the wire between the skin and the spar to keep it out of the way: do not pull it out!

A5 PITCH 40
(skins to spar)

A4 PITCH 40
(skins to rear ribs, tip ribs & nose ribs)

Two Grommets: one in the middle of the elevator spar, the other through the middle of the nose rib.
Re-install and cleco the nose skin, don't forget gusset 8H6-4 – rivet assembly

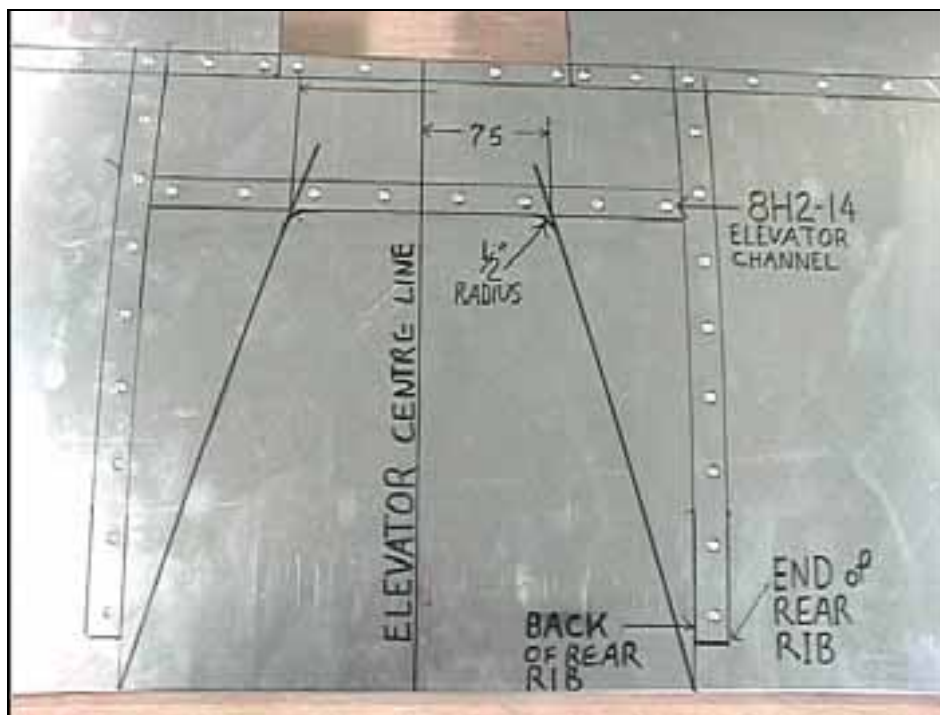

A5 RIVETS
THROUGH GUSSETS
8H6-4

NOTE: Elevator Cutout to make room for the rudder deflections.

LAYOUT CUT-LINE

- On the skin, mark the aft edge of the channel 8H2-14 (approximately 10mm from the rivet line)
- Extend the edge of the rear rib 8H1-7 to the trailing edge of the elevator.
- Front: Measure out 75mm left and right of the elevator center line.
- cut line: Connect the trailing edge line to the 75mm line
- Layout a 1/2" radius in the corner of the diagonal cutout and the channel.

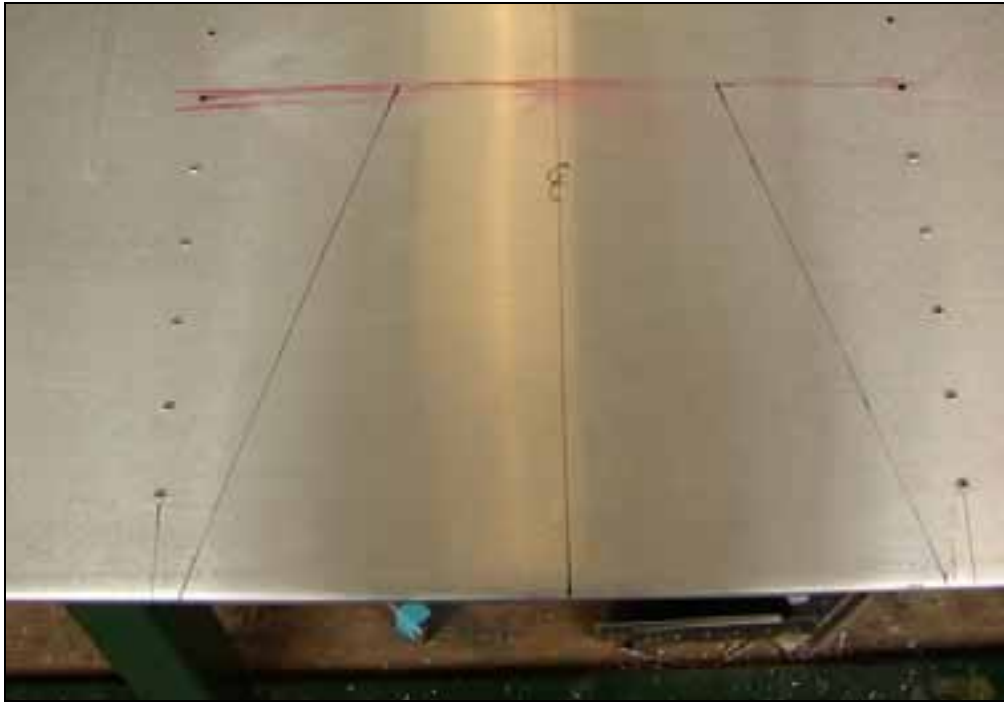

Location of cutline on trailing edge: approximately 10mm from rivet in through rear ribs 8H1-7
It's usually easiest to cut this out once the skin has been riveted into place.



With the snips, start cutting in the middle of trailing edge.

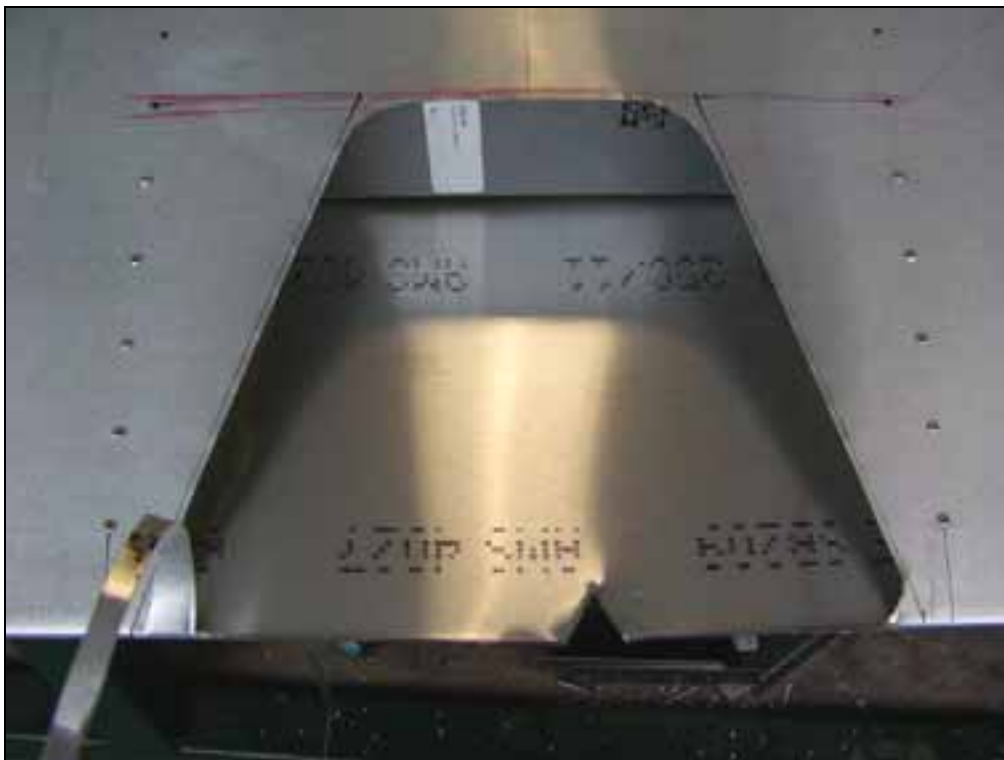

Best results are obtained by making the first cut at least 1-1/2" from the lines and then trimming progressively closer. Two to three trimmings are not unusual.



Start by making a small V cut in the trailing edge; cut through both the top and bottom side of the skin. Insert the snips between the skins, cut one side at a time.





Note: no filler ribs are required to close the sides of the elevator cutout.

Cut one side, then do the other side.

NOTE: notice the $\frac{1}{2}$ " radius, radius can be larger than $\frac{1}{2}$ ": suggest using a round or half round file to make radius.



File the edge of the cutout smooth to remove any sliver, bur or sharp edge.

CHECK: aft edge of the Gusset 8H6-4 will not interfere with the front edge of the L angle riveted to the Channel 8H2-14

Middle portion of the cutout, the edge of the skin must be trimmed a little past the web of the channel 8H2-14 to assure a flat mounting surface for the L angle riveted to the upper and lower Horns 8H5-1 and 8H5-2.